

Main Product Characteristics

| | |
|--------------|---------------|
| BV_{DSS} | 30V |
| $R_{DS(ON)}$ | 7.9m Ω |
| I_D | 55A |

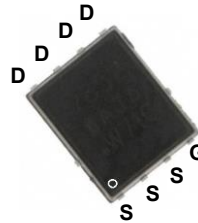

PPAK5X6

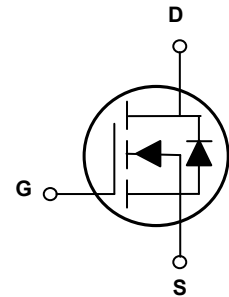

Schematic Diagram

Features and Benefits

- Advanced MOSFET process technology
- Ideal for high efficiency switched mode power supplies
- Low on-resistance with low gate charge
- Fast switching and reverse body recovery



Description

The GSFP0356 utilizes the latest techniques to achieve high cell density and low on-resistance. These features make this device extremely efficient and reliable for use in high efficiency switch mode power supply and a wide variety of other applications.

Absolute Maximum Ratings (T_C=25°C unless otherwise specified)

| Parameter | Symbol | Max. | Unit |
|--|-----------------|-------------|------|
| Drain-Source Voltage | V_{DS} | 30 | V |
| Gate-Source Voltage | V_{GS} | ±20 | V |
| Drain Current-Continuous (T _C =25°C) | I_D | 55 | A |
| Drain Current-Continuous (T _C =100°C) | | 35 | |
| Drain Current-Pulsed ¹ | I_{DM} | 220 | A |
| Single Pulse Avalanche Energy ² | E_{AS} | 45 | mJ |
| Single Pulse Avalanche Current ² | I_{AS} | 30 | A |
| Power Dissipation (T _C =25°C) | P_D | 47 | W |
| Power Dissipation-Derate above 25°C | | 0.37 | |
| Thermal Resistance, Junction-to-Ambient | $R_{\theta JA}$ | 62 | °C/W |
| Thermal Resistance Junction to Case | $R_{\theta JC}$ | 2.68 | °C/W |
| Operating Junction Temperature Range | T_J | -55 To +150 | °C |
| Storage Temperature Range | T_{STG} | -55 To +150 | °C |

Electrical Characteristics ($T_J=25^{\circ}\text{C}$ unless otherwise specified)

| Parameter | Symbol | Conditions | Min. | Typ. | Max. | Unit |
|---|--------------|--|------|------|-----------|------------|
| On/Off Characteristics | | | | | | |
| Drain-Source Breakdown Voltage | BV_{DSS} | $V_{GS}=0V, I_D=250\mu A$ | 30 | - | - | V |
| Drain-Source Leakage Current | I_{DSS} | $V_{DS}=30V, V_{GS}=0V, T_J=25^{\circ}\text{C}$ | - | - | 1 | μA |
| | | $V_{DS}=24V, V_{GS}=0V, T_J=125^{\circ}\text{C}$ | - | - | 10 | μA |
| Gate-Source Leakage Current | I_{GSS} | $V_{GS}=\pm 20V, V_{DS}=0V$ | - | - | ± 100 | nA |
| Static Drain-Source On-Resistance | $R_{DS(ON)}$ | $V_{GS}=10V, I_D=10A$ | - | 6.6 | 7.9 | m Ω |
| | | $V_{GS}=4.5V, I_D=6A$ | - | 9 | 11.7 | |
| Gate Threshold Voltage | $V_{GS(th)}$ | $V_{GS}=V_{DS}, I_D=250\mu A$ | 1.2 | 1.6 | 2.5 | V |
| Forward Transconductance | g_{fs} | $V_{DS}=10V, I_D=3A$ | - | 20 | - | S |
| Dynamic and Switching Characteristics | | | | | | |
| Total Gate Charge ^{3,4} | Q_g | $V_{DS}=15V, I_D=30A, V_{GS}=10V$ | - | 15 | 23 | nC |
| Gate-Source Charge ^{3,4} | Q_{gs} | | - | 1.8 | 3 | |
| Gate-Drain Charge ^{3,4} | Q_{gd} | | - | 4 | 6 | |
| Turn-On Delay Time ^{3,4} | $t_{d(on)}$ | $V_{DD}=15V, R_G=6\Omega, V_{GS}=10V, I_D=30A$ | - | 5 | 7.5 | nS |
| Rise Time ^{3,4} | t_r | | - | 13 | 20 | |
| Turn-Off Delay Time ^{3,4} | $t_{d(off)}$ | | - | 28 | 42 | |
| Fall Time ^{3,4} | t_f | | - | 8 | 12 | |
| Input Capacitance | C_{iss} | $V_{DS}=15V, V_{GS}=0V, F=1\text{MHz}$ | - | 900 | 1350 | pF |
| Output Capacitance | C_{oss} | | - | 130 | 200 | |
| Reverse Transfer Capacitance | C_{rss} | | - | 110 | 170 | |
| Gate Resistance | R_g | $V_{GS}=0V, V_{DS}=0V, F=1\text{MHz}$ | - | 2 | - | Ω |
| Drain-Source Diode Characteristics and Maximum Ratings | | | | | | |
| Continuous Source Current | I_S | $V_G=V_D=0V, \text{Force Current}$ | - | - | 55 | A |
| Pulsed Source Current | I_{SM} | | - | - | 110 | A |
| Diode Forward Voltage | V_{SD} | $V_{GS}=0V, I_S=1A, T_J=25^{\circ}\text{C}$ | - | - | 1 | V |
| Reverse Recovery Time | T_{rr} | $V_R=30V, I_S=10A, di/dt=100A/\mu s, T_J=25^{\circ}\text{C}$ | - | 110 | - | nS |
| Reverse Recovery Charge | Q_{rr} | | - | 170 | - | nC |

Note :

1. Repetitive rating: Pulsed width limited by maximum junction temperature.
2. $V_{DD}=25V, V_{GS}=10V, L=0.1\text{mH}, I_{AS}=30A, R_G=25\Omega, \text{starting } T_J=25^{\circ}\text{C}$.
3. Pulse test: pulse width $\leq 300\mu s, \text{duty cycle} \leq 2\%$.
4. Essentially independent of operation temperature.

Typical Electrical and Thermal Characteristic Curves

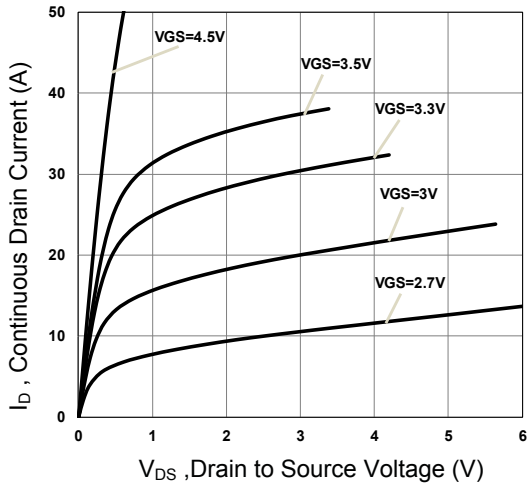

Figure 1. Typical Output Characteristics

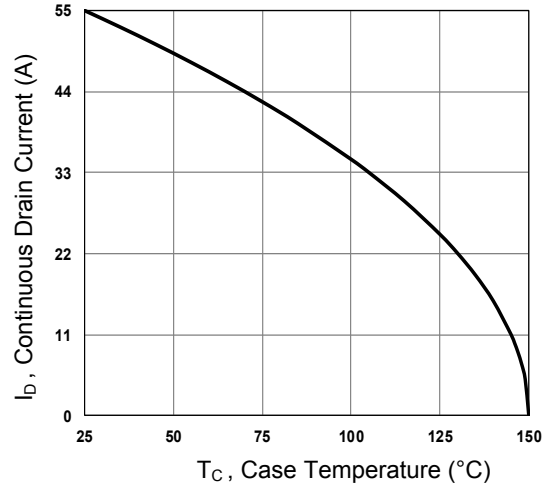

Figure 2. Continuous Drain Current vs. T_c

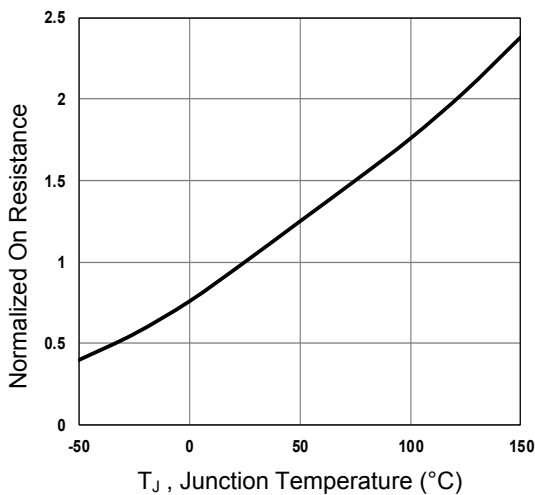

Figure 3. Normalized R_{DS(ON)} vs. T_J

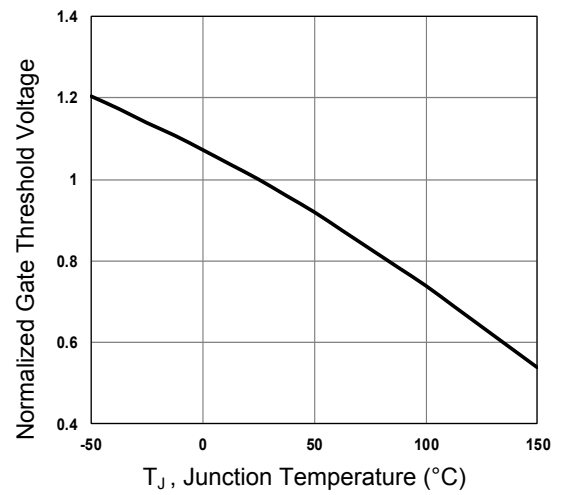

Figure 4. Normalized V_{th} vs. T_J

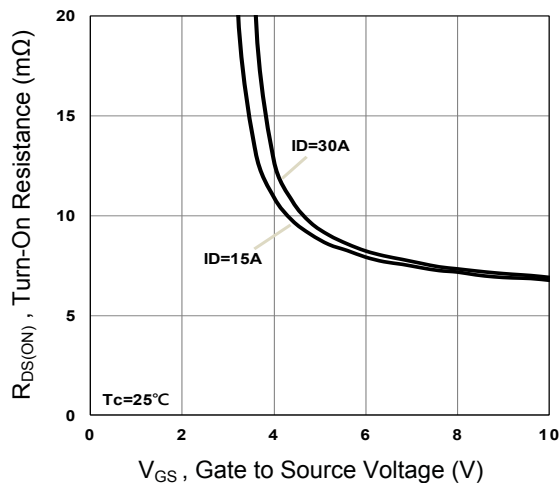

Figure 5. Turn-On Resistance vs. V_{GS}

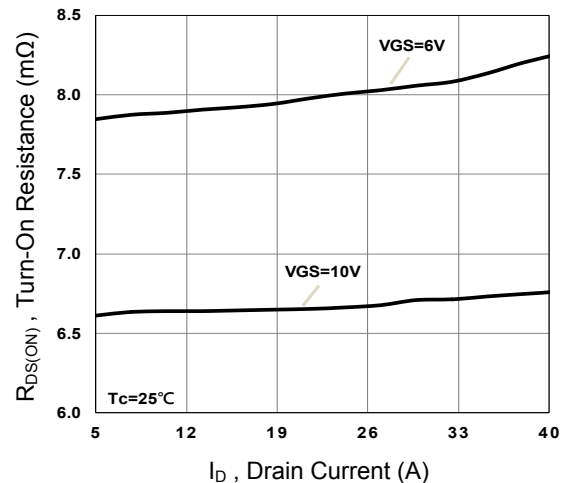

Figure 6. Turn-On Resistance vs. I_D

Typical Electrical and Thermal Characteristic Curves

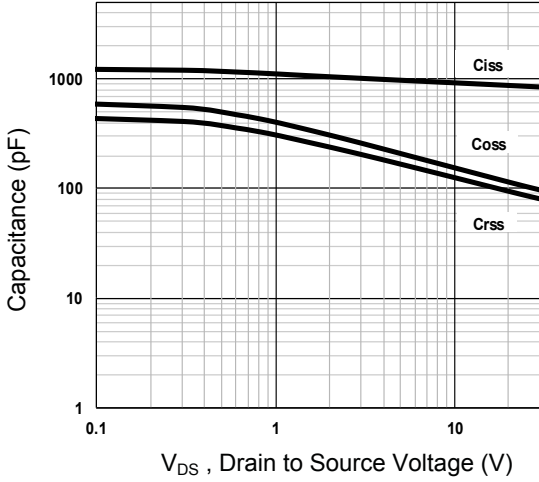

Figure 7. Capacitance Characteristics

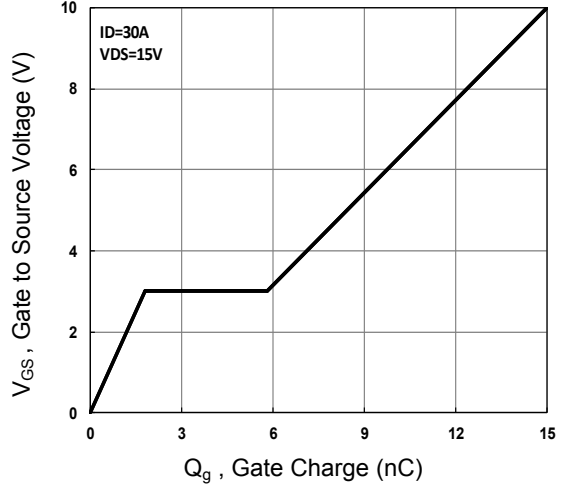

Figure 8. Gate Charge Waveform

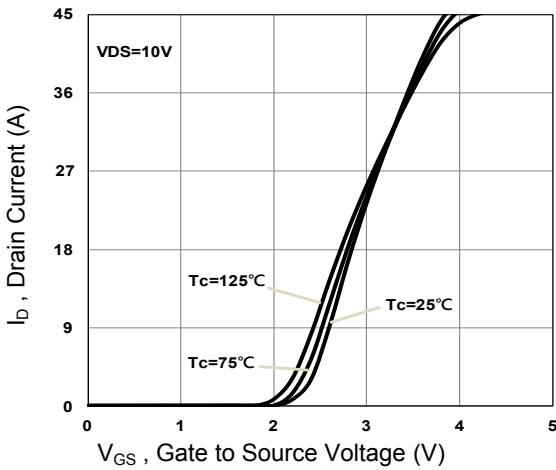

Figure 9. Transfer Characteristics

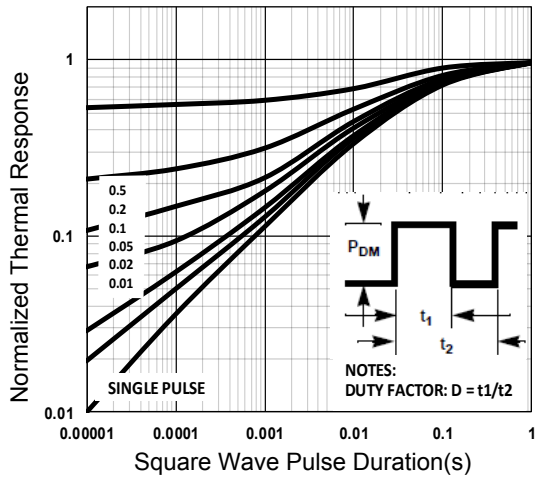

Figure 10. Normalized Transient Impedance

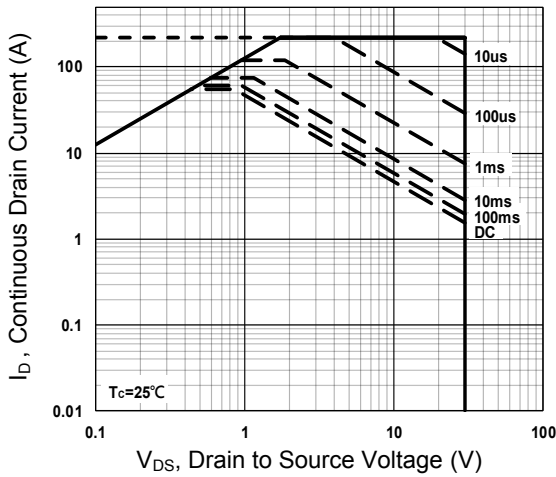

Figure 11. Maximum Safe Operation Area

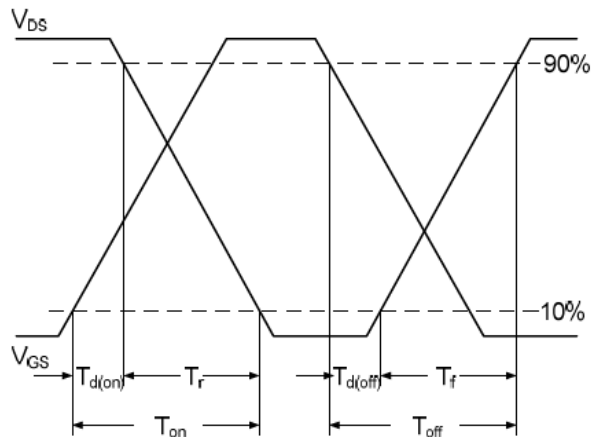

Figure 12. Switching Time Waveform

Typical Electrical and Thermal Characteristic Curves

$$EAS = \frac{1}{2} L \times I_{AS}^2 \times \frac{BV_{DSS}}{BV_{DSS} - V_{DD}}$$

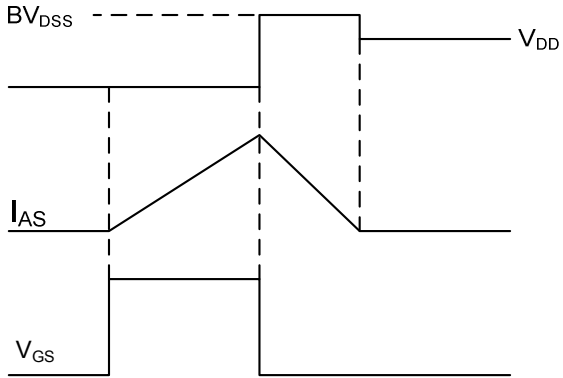
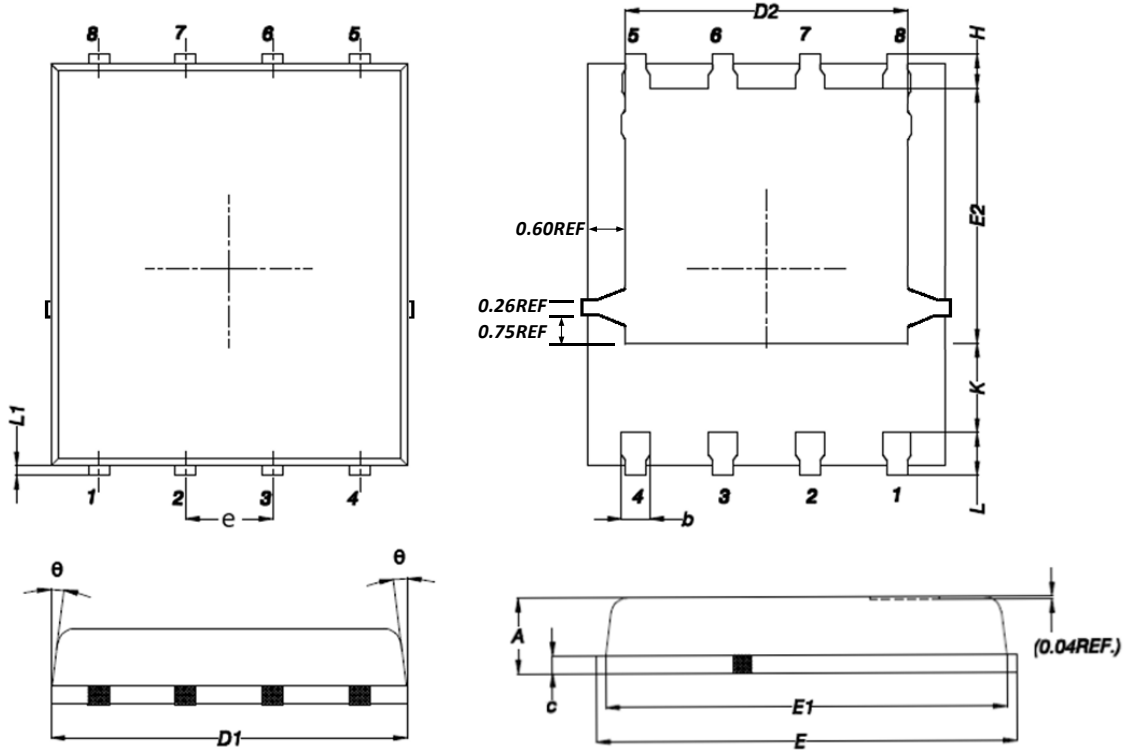

Figure 13. EAS Waveform

Package Outline Dimensions (PPAK5x6)



| Symbol | Dimensions In Millimeters | | Dimensions In Inches | |
|--------|---------------------------|-------|----------------------|-------|
| | MAX | MIN | MAX | MIN |
| A | 1.000 | 0.900 | 0.039 | 0.035 |
| b | 0.350 | 0.250 | 0.014 | 0.009 |
| c | 0.300 | 0.200 | 0.012 | 0.008 |
| D1 | 5.400 | 5.000 | 0.213 | 0.197 |
| D2 | 4.200 | 3.800 | 0.165 | 0.149 |
| E | 6.200 | 5.900 | 0.244 | 0.232 |
| E1 | 5.700 | 5.400 | 0.224 | 0.212 |
| E2 | 3.700 | 3.250 | 0.146 | 0.127 |
| e | 1.27BSC | | 0.05BSC | |
| H | 0.750 | 0.550 | 0.030 | 0.022 |
| K | --- | 1.100 | --- | 0.043 |
| L | 0.680 | 0.480 | 0.027 | 0.018 |
| L1 | 0.350 | 0.150 | 0.014 | 0.006 |
| θ | 12° | 0° | 12° | 0° |

Recommended Pad Layout

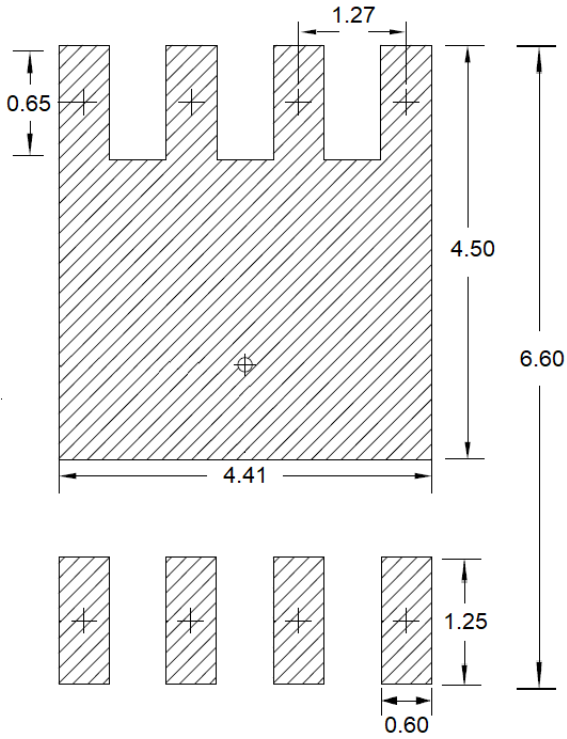

Order Information

| Device | Package | Marking | Carrier | Quantity |
|----------|---------|----------|-------------|--------------|
| GSFP0356 | PPAK5x6 | DC3944CX | Tape & Reel | 3000pcs/Reel |